

SGS

hope

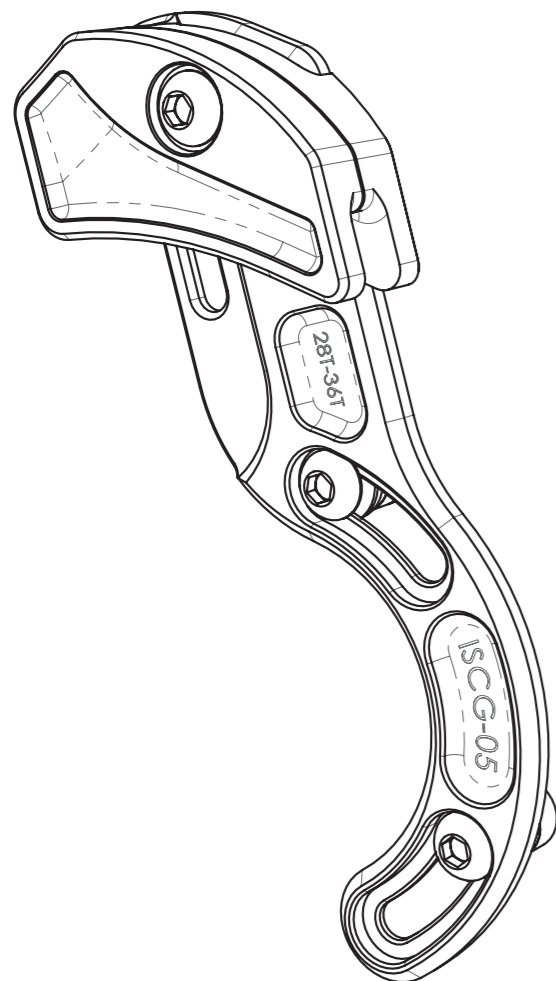

INTRODUCTION:

Thank you for acquiring our Hope Technology Slick Chain Guide Shorty version (S.G.S.) proudly designed, tested and manufactured in Barnoldswick, UK. This Chain Guide has been designed, developed and extensively tested through riders and customer feedback to combat issues known with current Chain Guides. If this product is installed correctly it will dramatically reduce the chances of your chain derailing from your front chainring. Every component has been optimised to give a light weight yet robust product from the CNC'd backplate and guide plates, to the stainless steel fasteners.

BOX CONTENTS:

See reverse of sheet for full exploded view of box contents and tools required to install this chainguide.

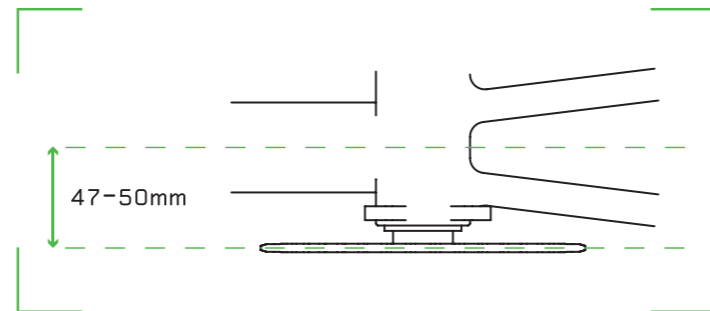

figure_001

CHAINLINE:

This chain device has been designed to work with the chainline between 47mm - 50mm.

This is calculated between the centreline of the frame and centre of the chainring [see figure_001.] Both the width of the frame, length of bottom bracket and mounting position of the chainring all have an effect on the chainline.

You must ensure this is correct before continuing with the installation.

INSTALLATION:

Installing a chainguide is very much a trial and error process to set up accurately due to variations in manufacturers components and tolerances. This guide only uses two of the three ISCG-05 mounting locations. The mounting location closest to the rear wheel is redundant when using this guide.

- Ensure the ISCG mounting tabs on your frame are clean (including the threaded holes) and the mounting faces are free of any debris which may cause the backplate to not mount parallel with the ISCG tabs.
- At this stage it's a good idea to check the depth of the tapped holes in the ISCG tabs. You will need as much thread engagement as possible to avoid them being damaged during your guides use. If your frames ISCG tabs have through holes, this is easier to measure the depth, as they can be visually seen. If your frame has blind holes we recommend using our longest 20mm screws (provided). Screw it into the tapped hole as far as it will go and measure the remaining thread visible from the mounting face of the ISCG tabs to the underside of the bolt head. Subtract this figure from the length of the bolt (in this case 20mm) and you will be left with your tapped depth. Do this for both holes as they may not be the same. Note down the figures for each to use later in the installation.

- As a starting point loosen the screw (holding the cage assembly together of your new chainguide) just enough for it to slide up and down.

- Place the chainguide backplate between the chainring and the frame (with the cage facing away from the frame).
- Place the cage over the chain / chainring [see fig_002] making sure the backplate is parallel with the ISCG tabs, then measure the gap between the backplate to the tabs. This will give you a rough idea of the offset and the size of washer required to space your guide properly.

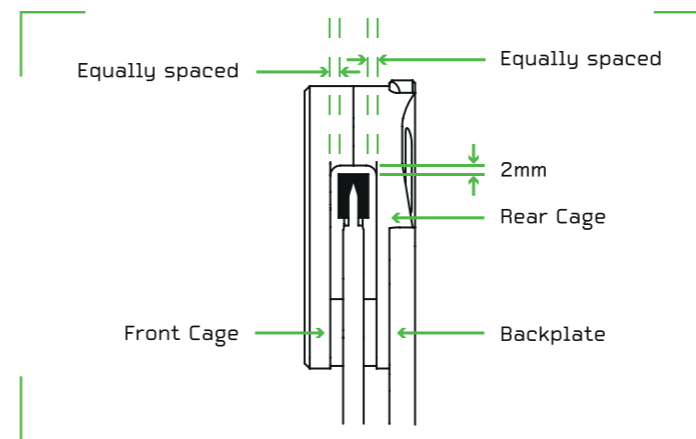
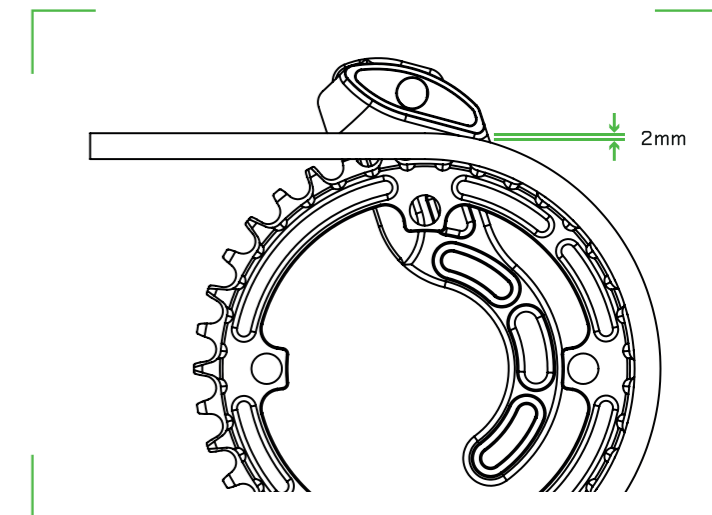

figure_002

- Now remove the guide and select your appropriate size washers. Using the 12, 16 or 20mm long M6 dome head screws (provided), push these through the slots in the front of the guide and place the washers on the back-side. Measure the length of thread protruding. This measurement should be as close to your maximum thread depth you recorded earlier, but must not exceed it. Use longer or shorter bolts as required.

- Grease the threads on the screws and mount the chainguide backplate to the ISCG tabs with the washers trapped between. Rotate the backplate so the screws are in the centre of the slots to start with, then lightly fix the screws to stop the backplate rotating. The cage can then be slid into place and

loosely fixed. The cage should be equally spaced either side the chain [fig_002] and the gap between the underside of the cage and chain should be approximately 2mm [see fig_003]



figure_003

- Only at this stage will you be able to see if your backplate is offset correctly. If not, you will need to swap the spacers and possibly the screws (provided) until the desired spacing is achieved.

- When in the largest chainring on your cassette, and the rear suspension is fully compressed, the ideal setup should allow the backplate to be rotated backwards as far as possible but not allow the chain to touch the cage. This will take a little fine tuning to achieve.

- Once in position torque the cage screw to 2-3 N.m. and the 2x backplate screws to 8-9 N.m.

- If set up correctly, the chain should not touch any part of the guide resulting in a slick friction free setup. Check the guide does not foul on any parts of the bike prior to using.

WARRANTY:

All Hope Technology components are covered for **one year from original date of purchase** against manufacturer defects in material and workmanship. Proof of purchase is required. Products must be returned to the original place of purchase or to Hope Technology to process any warranty claims. Please print and fill in the applicable returns form found on the **TECH SUPPORT** section of our website should you wish to send a product back. This warranty does not cover any damage caused through misuse or failing to comply by the recommendations in this manual. This warranty does not affect your statutory rights.

HOPE TECHNOLOGY

Hope Mill, Calf Hall Road, Barnoldswick, Lancashire BB18 5PX, United Kingdom

HEAD OFFICE

+44(0)1282 851400
info@hopetech.com

TECHNICAL

+44(0)1282 818413
service@hopetech.com

HOPETECH.COM



Backplate x 1
HCG010-01

Rear Cage x 1
HCG009-02

Front Cage x 1
HCG009-03

1.6mm Washer x 3
HBSP048-16

M6x20 Dome Head S/Steel x 3
M620DSS

TOOLS REQUIRED:

- Torque Wrench
- 4mm Allen Key

M6 Special T-Nut x 1
HCG001-05

4x 5mm Spacer
HCG010-02

2.5mm Spacer x 2
DTSP10236

0.8mm Shim x 2
HBSP048-8

M6 x 16 Dome Head S/Steel x 2
M616DSS

M6x12 Dome Head S/Steel x 2
M612DSS

